

**INSTALLATION ADJUSTMENT SERVICE
MEGATRON XL-200, XL-200-LF, XL-200-SW-LF
THERMOSTATIC
WATER MIXING VALVE**

IMPORTANT! Provide valve serial number, (located on valve cover) when ordering parts!!

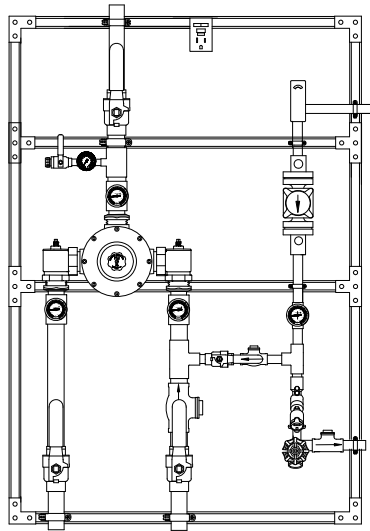

WARNING: This product can expose you to chemicals including lead, which is known to the State of California to cause cancer. For more information, go to www.P65Warnings.Ca.gov



INSTALLATION

1. Assembly should be installed at a location where it can easily be cleaned, adjusted or repaired.
2. The inlets are clearly marked on the valve body. Union angle strainer checkstops furnished must be installed on both supply lines as shown above.
3. Flush pipes thoroughly after system has been connected.
4. Refer to page 2 of this bulletin for correct Setup Instructions

125 PSI (8.6 BAR) MAXIMUM OPERATING PRESSURE

CAUTION

All thermostatic water-mixing valves have limitations. They will not provide the desired accuracy outside of their flow capacity range. Consult the flow capacity chart on page 5.

Minimum flow must be no less than as shown.

REMEMBER! THIS IS A CONTROL SYSTEM WHICH MUST BE CLEANED AND MAINTAINED ON A REGULAR BASIS (SEE MAINTENANCE GUIDE AND RECORD MGR-1000).

SETUP INSTRUCTIONS

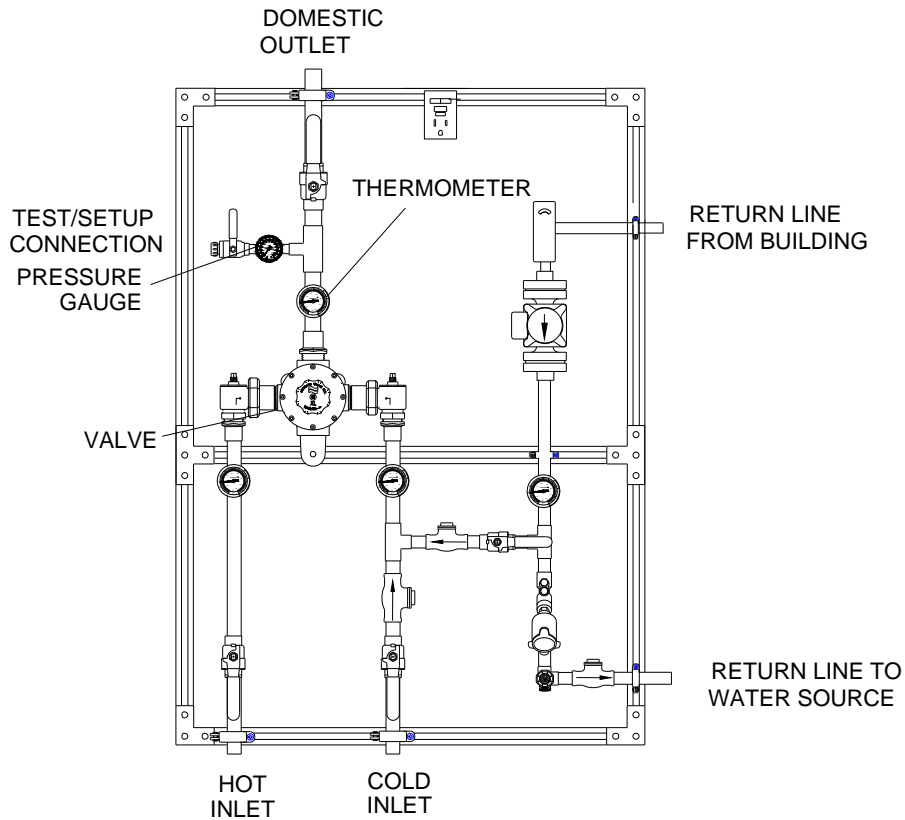

METHOD W SET-UP INSTRUCTIONS

Before any attempt is made to adjust this system, be sure the temperature of the hot water at the source is properly set and maintained.

1. Shut off circulator.
2. Open enough fixtures to flow a minimum of 5 GPM.
3. Set mixing valve to the desired temperature, (note Warning Tag attached to the pointer of the valve).
4. Shut off all fixtures. Note: At this point, be sure NO water is being drawn through any fixture until the temperature in the recirculated line has been set.
5. Fully open the circuit setter and start the circulator. Make sure no water is being drawn.
6. Observe the temperature until it stabilizes.
7. Close the circuit setter slightly if the temperature is too hot, and again let the temperature stabilize. Repeat until the desired recirculated temperature is set.

WARNING

WARNING! This Thermostatic Mixing Valve has an Locking Temperature Regulator (LTR) which must be checked. If the temperature is too high, the installer **MUST RESET** this adjustment immediately. Always check the temperature of the mixed water after installation. Excessively hot water is **DANGEROUS AND MAY CAUSE SCALDING!**

SERVICE

Leonard Type XL Thermostatic Water Mixing Valves are simple in design and may be easily cleaned, adjusted and repaired. If the installation is accessible, servicing may be completed without disconnecting the valve.

NOTE: Thermostatic Water Mixing Valves are REGULATING mechanisms, which must be regularly maintained to provide best performance. Frequency of cleaning depends on quality of local water conditions and usage. (See Maintenance Guide and Record MGR-1000).

TROUBLESHOOTING INSTRUCTIONS

ITEM:	PROBLEM:	RECOMMENDED REPAIR KITS:
PACKINGS & GASKETS	<ol style="list-style-type: none"> 1. Leak at stem. 2. Leak between valve cover and base. 	KIT 1/XL200
REBUILD	<ol style="list-style-type: none"> 3. Valve delivers either all hot or all cold water, or will not mix consistently. 	KIT R/XL200
CHECKSTOPS	<ol style="list-style-type: none"> 4. Hot water bypass into cold line. 5. Supplies cannot be shut off completely. 6. Leak at checkstop bonnet. 	KIT 2/200/C

WIRING DIAGRAM WITH LIGHTS

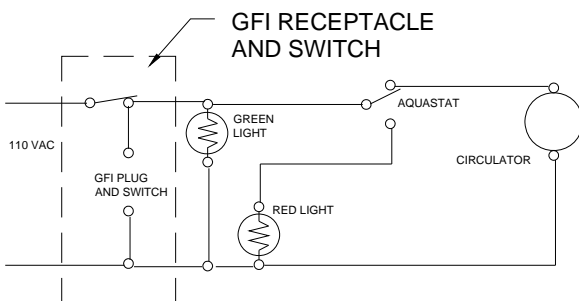

OBSOLETE

WIRING DIAGRAM NO LIGHTS

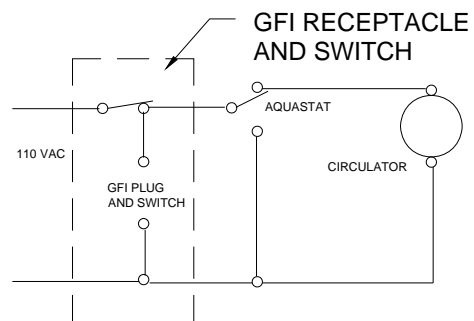

REMEMBER! THIS IS A CONTROL DEVICE WHICH MUST BE CLEANED AND MAINTAINED ON A REGULAR BASIS. (SEE MAINTENANCE GUIDE AND RECORD, MGR-1000).

KIT	KIT TYPE	INCLUDES
R/XL200	COMPLETE REPAIR	1-7
1/XL200	O-RING	2,3,6,7
2/200/C	CHECK	11-15

NOTE: DO NOT REMOVE
SNAP RING ON STEM

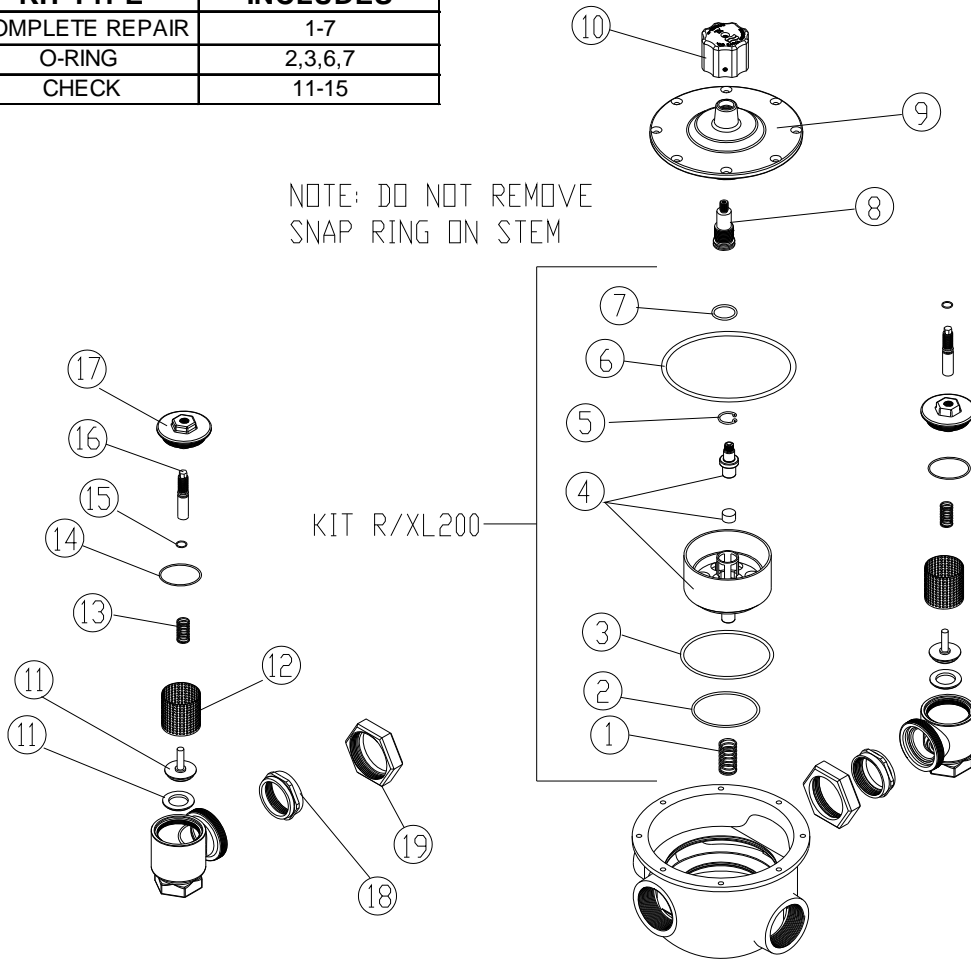

ITEM #	DESCRIPTION	QTY.	PART # / KIT #
1	SPRING, RETURN	1	KIT R/XL200
2	O-RING, LOWER SHUTTLE	1	KIT 1/XL200, KIT R/XL200
3	O-RING, UPPER SHUTTLE	1	KIT 1/XL200, KIT R/XL200
4	SHUTTLE ASSEMBLY	1	KIT R/XL200
5	RETAINING RING, COVER	1	7611, KIT R/XL200
6	O-RING, COVER	1	KIT 1/XL200, KIT R/XL200
7	O-RING, STEM	1	KIT 1/XL200, KIT R/XL200
8	STEM ASSEMBLY (DO NOT REMOVE SNAP RING)	1	781700
9	COVER	1	7856
10	KNOB ASSEMBLY	1	764000
11	LOWER STEM & PACKING	2	KIT 2/200/C
12	SCREEN	2	KIT 2/200/C
13	SPRING, CHECK	2	KIT 2/200/C
14	O-RING, BONNET	2	KIT 2/200/C
15	O-RING, UPPER STEM	2	KIT 2/200/C
16	STEM, UPPER CHECK	2	4727
17	CHECK BONNET	2	4723
18	SWIVEL (IF APPLICABLE)	2	4704
19	SWIVEL NUT (IF APPLICABLE)	2	4707

FLOW CAPACITIES

PRESSURE DROP											
MIN. FLOW	5	10	15	20	25	30	35	40	45	50	PSI
	0.3	0.7	1	1.4	1.7	2.1	2.4	2.8	3.1	3.4	BAR
5	69	96	117	135	148	163	174	188	198	208	GPM
18.9	216	363	443	511	560	617	659	712	750	787	l/min

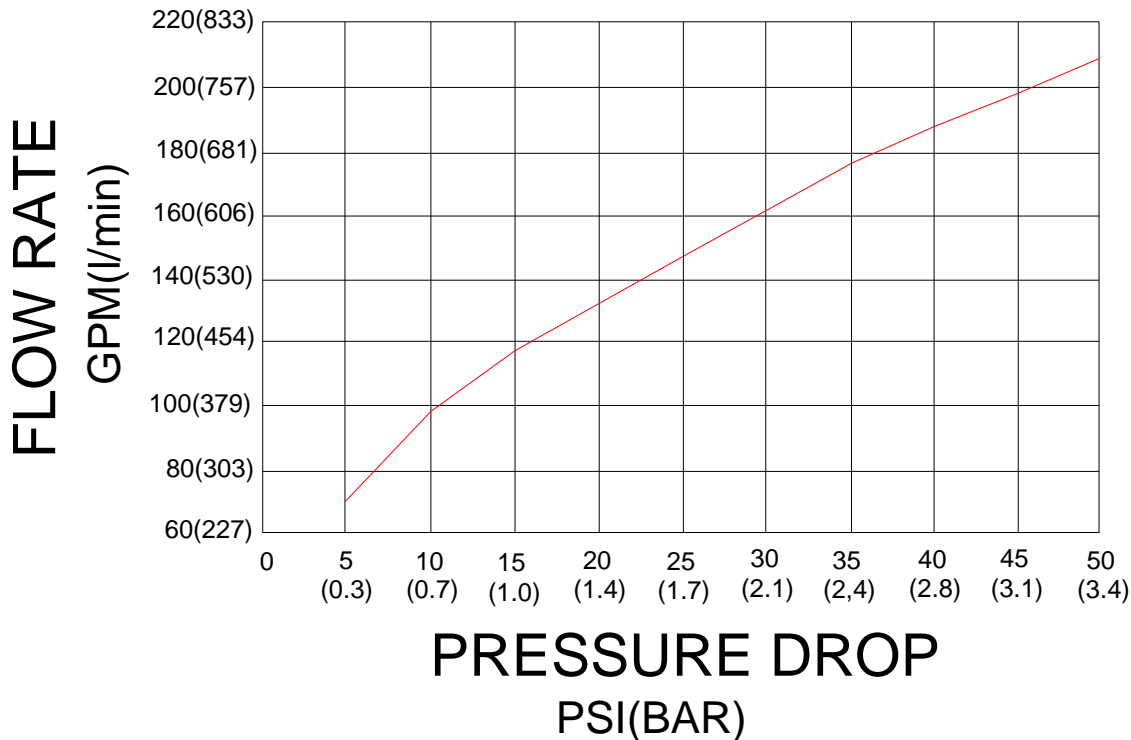

LIMITED WARRANTY

Leonard Valve Company warrants the original purchaser that products manufactured by them (not by others) will be free from defects in materials and workmanship under normal conditions of use, when properly installed and maintained in accordance with Leonard Valve Company's instructions, for a period of one year from date of shipment. During this period the Leonard Valve Company will at its option repair or replace any product, or part thereof, which shall be returned, freight prepaid, to the Leonard factory and determined by Leonard to be defective in materials or workmanship. There are no warranties, express or implied, which extend beyond the description contained herein. There are no implied warranties of merchantability or of fitness for a particular purpose. In no event will Leonard be liable for labor or incidental or consequential damages. Any alteration or improper installation or use of the product will void this limited warranty.

1360 Elmwood Avenue, Cranston, RI 02910 USA

Phone: 401.461.1200 Fax: 401.941.5310

Email: info@leonardvalve.com

Web Site: <http://www.leonardvalve.com>